

# **ST400 Series TACHOMETERS**

## **USER MANUAL**

(ST541004-011)



## Preface

### Congratulations

Congratulations on choosing a Stack Tachometer. This instrument will give you a wealth of track-side performance information to enable you to obtain the maximum from your vehicle.

### Registration Form

Please complete and return the registration form contained in the package. This will allow us to keep you up to date on the latest developments from Stack.

### Purpose of this manual

This manual will help you install your Tachometer. It explains how to set up and configure the system for your vehicle. The Tachometer models covered in this manual are as follows:

Tachometer Type	Standard 80mm (3.5in)	Monster 125mm (5.0in)	Classic 80mm (3.5in)	Classic 125mm (5.0in)
<b>Non Recording</b>	ST400-0 Min	ST430-0	ST400C-0	ST430C-0
<b>12 Minute 20Hz Recording</b>	ST400-12 Min	ST430-12	ST400C-12	ST430C-12
<b>25 Minute 10Hz Recording</b>	ST400-25 Min	ST430-25	ST400C-25	ST430C-25

### Related Products From Stack Limited

If you need information about other Stack motor sport products, these can be obtained from Stack or from your local Stack dealer. Products available from Stack include:

- Speedometers
- Boost Gauges
- Lap Timing Systems
- Analogue Sensors
- Digital Sensors
- Data Logging Systems
- Display and Logging Systems
- Display and Analysis Software

**STACK** is a registered trademark of Stack Limited. Information in this publication is subject to change without notice and does not represent a commitment on the part of Stack Limited. No responsibility is accepted for error or omission.

Copyright ©2000 Stack Limited

United Kingdom Telephone Numbers

Sales: 01 869 240 404

Tech. Support: 01 869 240 420

Fax: 01 869 245 500

North America Telephone Numbers

Sales: (888) 867 5183

Tech. Support (888) 364 2511

Fax: (888) 364 2609

## **CONTENTS**

<b>PREFACE</b>	<b>1</b>
<b>INTRODUCTION</b>	<b>3</b>
<b>INSTALLATION</b>	<b>4</b>
MECHANICAL INSTALLATION	4
ELECTRICAL INSTALLATION	4
SETTING CYLINDERS	4
INSTALLATION NOTES	5
TESTING	6
<b>OPERATING THE TACHOMETER</b>	<b>6</b>
GENERAL	6
STANDARD TACHOMETER FUNCTIONS	6
RECORDING TACHOMETERS FUNCTIONS	10
<b>TECHNICAL SPECIFICATIONS</b>	<b>13</b>
Appendix A - Connection Details	14
Appendix B - Model Feature Table	15
Appendix C - Troubleshooting	16
Appendix D - Cylinder - Dial chart	19
Returned Goods Procedure	20

## **INTRODUCTION**

The range of STACK Logging Tachometers has been designed and developed from the highly successful, award winning STACK Intelligent Tachometer.

The full power of the in-built microcomputer, which is found at the heart of all STACK tachometers, has now been utilised for data analysis as well as driver display and data recording.

Also in common with the range of highly respected Stack Intelligent Tachometers, the driver display consists of a high precision positive drive mechanism, which ensures accurate information is being displayed under all circumstances.

Within this range of instruments there are three different models, each having its own combination of available features. The recording models have the ability to download data, via the in-built RS232 interface, to a PC for analysis.

The full list of features available on tachometers within the range is as follows:

- \* **Positive needle RPM display**
- \* **Maximum RPM tell-tale**
- \* **Shift RPM or 'Fast Lap' indicator**
- \* **'Action Replay' on-dial display of recorded data**
- \* **Lap times recording**
- \* **25 minute 10Hz or 12 minute 20Hz recording rate**

The information produced by the tachometer should, if used wisely, enable the user to implement changes to the vehicle that will improve the overall performance.

### **Standard Tachometer Items**

The Tachometer is supplied with the following standard components:

<i>Quantity</i>	<i>Description</i>	<i>Part No</i>
1	ST4xx Series Tachometer	as supplied
1	Tachometer Fixing Kit (Including the following)	ST584
1	Switch Kit (2 switches)	ST510
1	Panel mount Fast-Lap/Shift Light	ST537
1	Tachometer Harness	ST594
1	Tachometer User Guide (This Document)	ST541004

## **INSTALLATION**

### **IMPORTANT**

After installation you will need to **set the number of cylinders** before the Tachometer can show the correct engine RPM. (See SETTING CYLINDERS)

### **MECHANICAL INSTALLATION**

1. The tachometer should be fitted in an 80mm (3.15in) diameter hole or a 116mm (4.6") diameter hole (ST430 models only) and secured using the fixing bracket supplied. It may be mounted in the hole at any angle of rotation for best viewing by the driver.
2. The 2 switches **MUST** be installed for the Tachometer configuration and functions to be available. Take care in positioning these 2 switches, as they need to be pressed simultaneously for some functions.  
Label the switches '**M**' for **Max**, lap **Marker** and '**R**' for **Run, Reset**.
3. The Shift Light should be fitted in a position where it can easily be seen by the driver whilst driving.

### **ELECTRICAL INSTALLATION**

The tachometer is supplied with a fully wired harness to simplify wiring.

1. Fit the connector into the rear of the Tachometer.
2. Fit the leads marked '**M**' and '**R**' to the two switches.
3. Fit the lead marked '**SL**' to the Fast-Lap/Shift Light.
4. The long red (**B+**) and black (**B-**) wires should be connected to the battery Positive and Negative respectively.

**Note: This tachometer is for use on NEGATIVE earth vehicles only.**

5. Connect the long orange Pulse Pickup lead marked '**P**' to the coil negative terminal or the tachometer output from the Engine Management system.  
Appendix A. contains connection information for common ignition systems regarding pin identification and wiring.

### **SETTING CYLINDERS**

The Tachometer, when shipped, is set for 1 Cylinder (4 stroke) operation.

If you do NOT require this setting then you will need to set the correct number of cylinders as follows:

1. Press and **Hold** both the **Max** and **Run** switches.
2. Apply power to the Tachometer and release the buttons. The needle will display the Cylinder-RPM. (see the Cylinder Dial chart in Appendix D).
3. For **4 Stroke engines**: Press the **Max** switch the same number of times as the number of cylinders required. e.g. 4 times for 4 cylinders.  
For **2 Stroke engines**: Press the **Max** switch double the number of times as the number of cylinders required. e.g. 8 times for 4 cylinders.  
(**Note**: The needle will drop on the 1st **Max** switch press, to show 1 cylinder, and move up for each subsequent **Max** button press)
4. Do not press either switch for 3 seconds. The Tachometer will set the number of cylinders in its memory, and the needle will return to Zero RPM.

**Notes:**

The number of cylinders can be checked by carrying out steps 1 & 2.

Once set, the tachometer will remember the correct number of cylinders.

If during the setup the 3 second timeout occurs before the correct number of cylinders has been set, power off the tachometer and start again.

The **Max** switch is deliberately 'Slowed' to ensure the correct number of presses are counted. DO NOT try to press the switch too rapidly.

**INSTALLATION NOTES**

The following Installation notes will help ensure good results if wiring the tachometer with your own harness:

- Connector** The plastic connector has the pin numbers marked on the wire entry face. These may be used to ensure correct connection. If additional wires are required they should be insulated, multi-stranded cable of minimum current rating 5 Ampere
- Supply** The supply to the tachometer should be within the range 8-16 volts DC - Positive connection to Pin 1 and negative to Pin 3. Pin 3 should be connected to the negative of the battery, either directly, or by connecting to existing wiring. Indirect connections to the vehicle chassis cannot be relied upon.
- Input** The pulse input to the tachometer (pin 2) should either be connected to the dedicated tacho output of the ignition system, if this exists, or to the low tension (negative) side of the coil. Appendix A contains some information on recommended connections to common ignition systems.
- Switches** The switches supplied with the system are of a 'momentary action normally open' type and should be connected to the switch input on the 9 way connector and battery negative. Additional switch kits are available from Stack - request Part No. ST510.
- Outputs** Each of the two outputs (pins 4 and 9) is an 'open-collector transistor' type. This is probably best thought of as an electronic switch connected on one side to battery negative. The load on either output should therefore be connected between battery positive and the relevant output. The maximum current which may be switched via either output is 0.2 Amperes and therefore they may be used to drive a lamp directly or larger loads and/or other equipment via a relay.
- The output on pin 9 is turned 'on' whenever the tachometer is recording and the output on pin 4 is controlled by the adjustable Shift RPM setting - please refer to the "OPERATING THE TACHOMETER" section for more information.

## TESTING

Once the installation has been completed the tachometer may be powered up. When power is applied the needle should initially move to behind the Stack logo, when a slight buzz may be heard, and then be driven forward and stop at the zero RPM position. The green LED behind the STACK logo should be illuminated as a backlight.

Start the engine and watch the tachometer. As the throttle setting is gradually increased the needle should rise in small steps and when the RPM is held steady should show a reasonably constant reading.

If the tachometer is powered off with the engine still running, the needle will stay at whatever RPM was being displayed when the power was removed. Further tests may only be carried out after reading the following chapter.

## OPERATING THE TACHOMETER

### GENERAL

All functions of the Tachometer are accessed via the two push-button switches attached via the 9 way connector. The main functions which are accessed in this way are as follows :

* <b>Tell-tale maximum display</b>	<b>All tachometers</b>
* <b>Reset tell-tale display</b>	*
* <b>Shift RPM or 'Fast Lap' indicator</b>	*
* <b>Recording start/stop</b>	<b>Recording tachometers</b>
* <b>Lap timing</b>	*
* <b>Recording memory clear</b>	*
* <b>Action Replay</b>	*

## STANDARD TACHOMETER FUNCTIONS

### Switch Functions

All the functions of the Tachometer are obtained by pressing one or both of the push button switches, labeled **Max** and **Run**. Certain functions depend on how long you press a switch or combination of the two switches. These functions and the switches that obtain them are given in the following table:



Functions available on **all Tachometers**

Standard Function	Max RPM	Run/Stop Reset	Time Pressed	Comments
<b>Record Lap Marker</b>			As Required	Red LED blinks. Press button for less than 0.5Sec to avoid Max RPM being displayed
<b>Max RPM</b>			More than 0.5Sec	Red LED Blinks to indicate Lap marker recorded
<b>Reset Max</b>			5 Sec	Needle moves to full scale. Release key before needle reaches ZERO
<b>Set Fast Lap or Shift RPM</b>	→		3 Sec	Tacho may starts Action Replay & then Shift light comes on
Increase RPM			As Required	Move needle to required Shift RPM Note: Set Shift RPM to ZERO to Enable Fast Lap feature
Decrease RPM			As Required	
Exit			3 Sec	Neither button pressed - needle reads actual RPM
<b>Self Test</b>	→		5 Sec	RED LED's flash. Needle moves to full scale & to zero then to each mark.
<b>Tacho Reset</b>	→		On power UP	Press & hold Max & Run Switches then apply power (e.g.Turn ignition on) Do NOT press any key for 3 seconds

Key Press Sequence			
	=		Press Max RPM Switch Only
	=		Press Run/Stop Switch Only
→	=		Press & hold Max Switch Then press Run switch

## General Operation

### Display RPM

The tachometer will always show the current RPM value of the engine, regardless of any other functions being performed simultaneously, unless the dial face is being used by that function. e.g. Show Max, Action Replay, Set Cylinders & Set Shift RPM.

### View Maximum RPM

The maximum value of RPM measured will be continuously updated automatically and may be viewed by simply pressing the **Max** switch. The value displayed will be the highest value measured since the tell-tale memory was last reset.

### Reset Maximum RPM

The tell-tale may be reset at any time by using the **Run** switch. This switch should be held pressed for approximately 5 seconds until the needle moves to maximum RPM and not released until the needle starts to fall. It must be released before the needle reaches zero.

### Set Shift RPM

There is a Shift RPM setting which may be adjusted using the dial and switches attached to the system.

This Shift RPM limit controls the electrical output on pin 4 of the 9 pin connector. The output will switch 'ON' whenever the shift RPM is exceeded and can be used to switch a lamp to indicate over-rev, or to trigger a rev-limiter etc.

To set the shift RPM press and holding down the **Max** switch, then press the **Run** switch. Hold down both switches for 2 seconds. The needle will then move to show the current shift RPM.

This shift RPM may be adjusted at this time by using the two switches individually. The **Max** switch will increase the shift RPM setting and the **Run** switch will reduce it.

When the tachometer detects that neither switch has been pressed for 3 seconds it will exit the shift RPM setting mode.

---

**Enable Fast Lap**

The Fast-Lap feature gives the driver an indication each time a lap is completed which was faster than any previous lap within the current run. The Fast-Lap/Shift Light output, on pin 4, will switch 'ON' whenever a new fastest lap occurs. This function requires the tachometer to be connected to a STACK Lap Marker system or for the driver to manually identify Laps by pressing the **Max** switch.

Setting the Shift RPM limit to Zero will enable the Fast-Lap function.

To enable the Fast-Lap feature press and hold down the **Max** switch, then press the **Run** switch. Hold down both switches for 2 seconds. The needle will then move to show the current shift RPM. Move the needle to Zero by pressing and holding the **Run** switch.

**Self-test Functions**

The correct operation of the tachometer may be confirmed at any time using this feature. The tachometer is put into 'Self-Test' mode by first pressing and holding down the **Max** switch, pressing the **Run** switch and then continuing to hold down both switches for 5 seconds, until the red Run LED begins to flash. It should be noted that during these 5 seconds the dial will show the Shift RPM setting.

Once the operation of the LED has been seen, the switches may be released and the dial should then move to full scale, back to zero and then step to full scale again, this time in increments of 500 or 1000 RPM.











The Shift light will come on for the last 2 steps to test the light (e.g. 9000 and 10000 RPM for a 0-4000-10000 dial), regardless of the Shift RPM setting.

**Reset Tachometer**

The Reset Tachometer feature may be used to reset the memory of the tachometer at any time. This will include the memories for the maximum tell-tale, recorded RPM data, lap-times, and the shift light RPM setting. The tachometer is reset by pressing and holding both the **Max** and **Run** switches while power is applied. Then release the switches and **do NOT press either switch again for 3 seconds**. During the 3 seconds the needle will move to a position on the dial to indicate the No. of Cylinders setting (see SETTING CYLINDERS). After 3 seconds, the needle will reset to zero RPM.

## RECORDING TACHOMETERS FUNCTIONS

### Switch Functions

Recording Functions	Max RPM	Run/Stop Reset	Time Pressed	Comments
<b>Start Recording</b>			Less than 2 Sec	Run LED turns ON
<b>LAP Marker</b>			Less than 0.5 Sec	Run LED blinks
<b>Stop Recording</b>			3 Sec	OR by removing power. Run LED turns OFF
<b>Clear Memory</b>			7 Sec	Needle moves to full scale (FSD) and returns to ZERO
<b>Start Replay</b>			Less than 2 Sec	Action replay begins
<b>Speed Up Replay</b>			As Required	
<b>Slow Down Replay</b>			As Required	
<b>Stop Replay</b>			Less than 2 Sec	Action replay aborts

### General Operation

The recording time available in the Tachometer varies according to the individual model type. Appendix B contains detailed information regarding each of these.

The Tachometer will automatically start recording once the engine RPM exceeds a given value (See Start Recording) and continue to record until the engine RPM is zero for 10 seconds or more or the recording is stopped manually.

The recording memory is used for storing the engine RPM data and Lap times for subsequent analysis. As each recording is started and stopped, a data block is created in memory called a 'RUN'.

This 'RUN' will be broken down into 'LAPS' if the relevant markers were added during the recording. The number of separate runs which may be stored is effectively limitless, the total recording time being the only restricting factor.

Following analysis of the data, the memory may be cleared to make the total size available once again for new data. If the memory should fill up during data collection, the tachometer will automatically stop recording. The memory must then be cleared, after any necessary data replay or download has been obtained, before being used again.

The red LED, situated behind the STACK logo on the glass front panel, is used to indicate whether the tachometer is in recording mode or not. When in this mode it is also used to indicate that a marker has been received.

The 'Recording' electrical output is switched in parallel with the red LED and if an external lamp has been connected it will indicate recording status to the driver. For more information regarding connections to this output please refer to the section titled "Installation notes" in this manual.

**Start Recording** The Tachometer will automatically start recording when the engine RPM rises above either:

50% of the highest RPM marking on the dial face for normal dials or ...

The first large RPM marking on the dial face for expanded dials (i.e. low revs compressed)

The tachometer can also start recording by a short press of the **R**un switch. This press must be less than 2 seconds  
The red LED behind the STACK logo will be turned on as will the 'Recording' electrical output on pin 9.

**Lap Markers** Once the tachometer is in recording mode a short press of the **M**ax switch will enter Lap markers into the data.

These markers, once recorded will appear in data and may be used for calculation of lap times if the model of Tachometer supports this.

The STACK Infra-red Beacon System may be connected to the **M**ax switch input and will perform the marker function accurately and automatically with obvious advantages.

The red LED behind the STACK logo and the 'Recording' electrical output will be turned 'OFF' for a short period. The LED will therefore appear to 'blink' when a Lap marker is received.

If the Fast-Lap function is enabled the Fast-lap/Shift lamp will be turned on for 8 seconds if the lap time just completed is the fastest in the current recorded run. If the lap time isn't the fastest in this run the Fast-Lap/Shift Lamp will remain turned off.

**Stop Recording** The tachometer will automatically stop recording if the engine RPM falls to zero for 10 or more seconds (unless the recording was manually started). Recording may also be stopped at any time either by pressing the **Run** switch for 3 seconds or by removing power from the tachometer or when the recording memory is full.

The red LED behind the STACK logo and the 'Recording' electrical output will both be turned 'OFF'.

If Lap Markers are entered when Recording is stopped, the red LED and the 'Recording' electrical output will both be flashed on for a short period, appearing to blink.

The Fast-Lap feature will continue to operate even after recording has stopped if it is enabled.

**Clear Memory** The memory may be completely cleared by pressing the **Run** switch until the needle moves to maximum RPM on the dial and **MUST** then be held until the needle has returned fully to the zero RPM whereupon it may be released. This will clear all previously recorded information.

### Action Replay Operation

The tachometer is capable of displaying the recorded data by replaying data on the dial face.

**Note:** Instructions for downloading to a PC are included with the PC Download Package.

**Start Replay** Replay is initiated by pressing and holding down the **Max** switch, pressing the **Run** switch and then continuing to hold down both switches until the Needle responds.

**Lap Markers** If Lap markers were entered during data recording, these will be displayed by a flash of the red LED, at the appropriate time, during replay.

**Replay Speed** The rate of display of data on the dial may be changed by pressing and holding either the **Max** switch or the **Run** switch respectively. The effect of pressing the switches is as follows:

Switch Pressed	All 12 & 25 min recording models Speed of Display
Max	Double recorded rate
Run	Half recorded rate

This can be used to 'fast forward' through unimportant data to the area of interest and then to look at this data in 'slow motion' for more detailed analysis.

**Stop Replay** The output may be aborted at any time by pressing and holding down the **Max** switch, pressing the **Run** switch and then continuing to hold down both switches until the Needle responds.

## TECHNICAL SPECIFICATIONS

### ALL MODELS - Unless otherwise specified

Operating Temperature	-20 deg C to +70 deg C
Storage Temperature	-40 deg C to + 80 deg C
Accuracy	Linear dials +/- 0.6% over temperature range Non linear dials +/- 0.45% over temperature range
Humidity	0-95% Non-condensing
Vibration	10-55Hz 5mm pk; 55Hz-1KHz 30g 12 hours
Supply	0.25 Amperes @ 8-16 Volts D.C.
Nett Weight	<b>ST400:</b> 400 grams; <b>ST430:</b> 475 grams
Dimensions	<b>ST400:</b> 88mm (3.5in) diameter x 75mm (3.0in) deep <b>ST430:</b> 123mm (4.9in) diameter x 75mm (3.0in) deep
Fixing details	<b>ST400:</b> 80mm (3.15in) diameter cut-out <b>ST430:</b> 80mm (3.15in) or 116mm (4.6in) diameter cut-out
Backlighting	Solid-state green LED
Shift RPM Limit	User adjustable within the range of the dial face
Electrical Outputs	Pseudo open collector type (200 mA current sink maximum switched to battery negative)

### ST400-12 Min/ST430-12 Min

Record Capacity	12 Minutes
Record Interval	0.05 Seconds (20Hz)
Record Accuracy	+/- 0.25% over total temperature range

### ST400-25 Min/ST430-25 Min

Record Capacity	25 Minutes
Record Interval	0.1 Seconds (10Hz)
Record Accuracy	+/- 0.25% over total temperature range

Appendix A - Connection Details

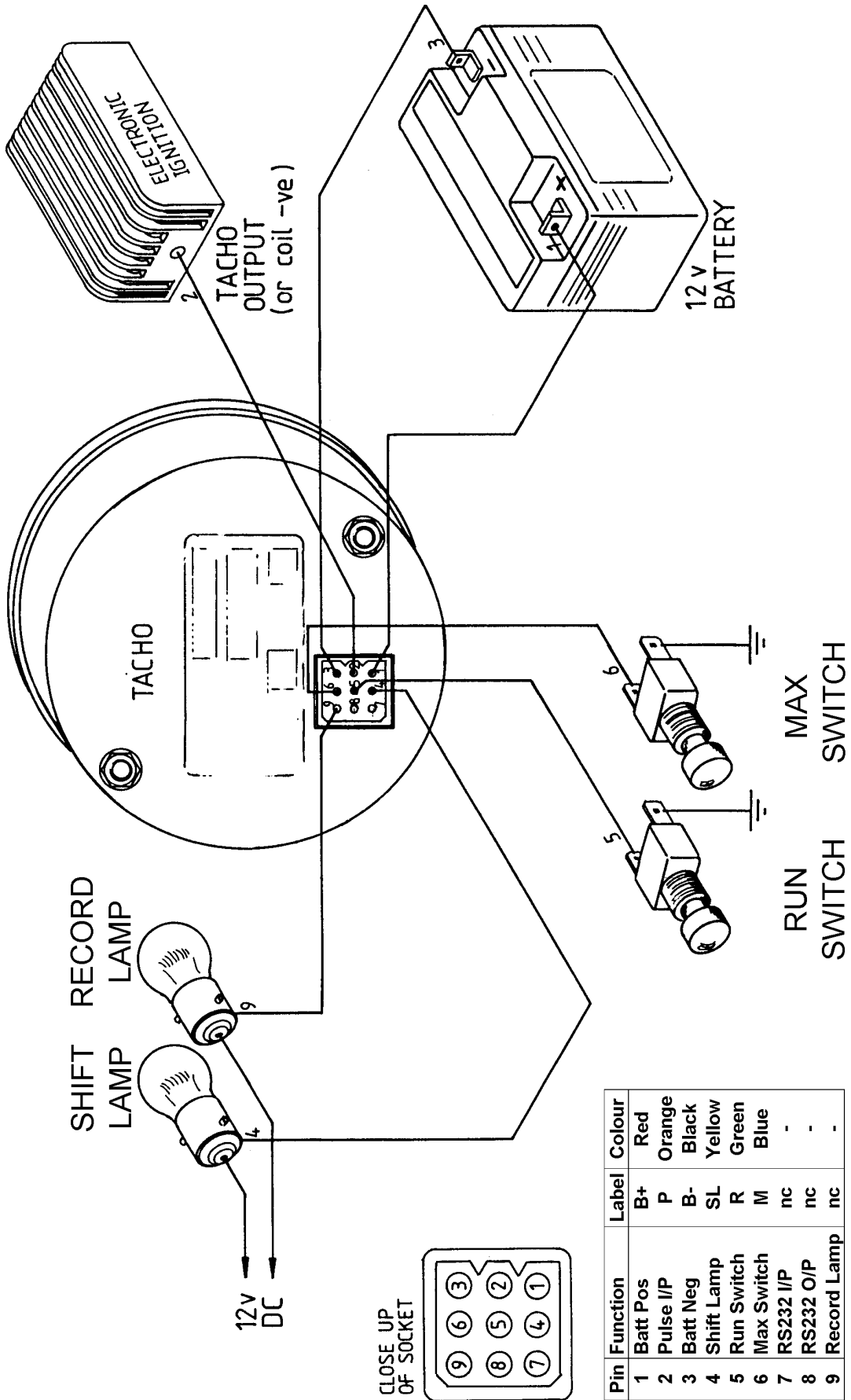



## Ignition System Connection Table

IGNITION SYSTEM	NORMALLY FITTED TO	CONNECTION POINT
Lumenition Performance (Black)	Accessory only	Blue wire from distributor pick-up
Lumenition Optronic MK17 (Silver)	Accessory only	Brown wire on coil negative
Lucas CD racing (Sparkbox)	F3000	Connector 'C' pin 1 (7 pin)
Sodamo engine management	Formula Renault	White wire on coil negative
Cosworth ECU	DFR89	ECU connector pin 'N' plus a 1K0 resistor from 'N' to +12v
Bosch 8 pin CD	Porsche 930 Turbo '76	Pin 7 on ignition unit
Bosch 3 pin CD	Porsche 911 Carrera '76	Pin 'C' (points connection)
General Mtrs GME-071	Formula Vauxhall/Lotus	Tacho output (coil negative) with 10K series resistor
'Contactless'	Accessory only	Dedicated tacho output
Zytek ECU	Accessory only	Dedicated tacho output
Bosch	Citroen AX 'Sport' and 'GT'	Tacho output (coil negative) with 100K series resistor

### Series resistor connection

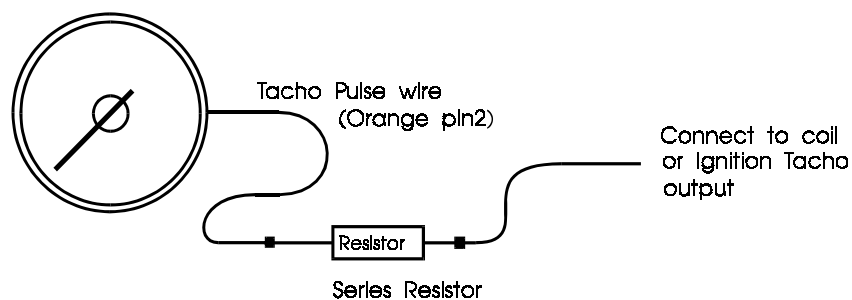

## Appendix B - Model Feature Table

	ST400 & ST430 (including classics)
Adjustable Shift Light output	✓
Fast Lap output	✓
Action Replay	✓
Data Transfer to PC (Requires ST527 Package)	✓

**Appendix C - Troubleshooting**

No.	Symptom	Possible Cause	Remedy	Notes
	<b>Tacho Operation</b>			
1	Display is dead or needle resets-vibrates or No green backlight	Battery is dead or almost dead	Recharge or replace battery	Check if battery is connected. Check power lead continuity
2	No RPM reading or Tachometer reading erratic, needle jumps high or low (See Below)	Incorrect wiring.	Check the connection of the Pulse wire to the Coil Negative or the engine management system	See instructions for the engine management system for tacho connection details
3	Tachometer reading erratic, needle jumps high or low (See 4&5)	Coil requires RFI suppression capacitor	Fit RFI suppression capacitor	
4	Tachometer reads OK at low revs, reading erratic, needle jumps high or low at higher revs	Points bounce on Coil & point ignition systems	Replace or readjust Points.	If possible increase tension on points spring
		Coil & point ignition systems, inadequate earthing of engine block	Check for good chassis earth to engine block.	(Install earth strap)
		Hi power electronic ignitions. Inadequate earthing of ignition system	Use heavier gauge power leads from the battery to the ignition pack.	Connect tacho negative supply close to the ignition system negative supply/ battery/chassis connection
			Check for good chassis earth to engine block.	(Install earth strap)
5	Tachometer reads erratic at medium RPM with a Constant energy Electronic Ignition system. Signal taken from coil	Tacho is seeing the pulse timing changes from the ignition system	Add a 47k resistor in line with the pulse lead to the tachometer	47k 1/4watt 5% or 10%, should be rated to 500v
6	Tachometer powers up OK but resets constantly when the engine is running	Intermittent supply wiring to tacho.	Check the 9w Pins & sockets for dirt. Check sockets for damage or if opened out	
		Coil requires RFI suppression capacitor	Fit RFI suppression capacitor	
		Battery failing under vibration or load.	Replace battery with known good unit	

No.	Symptom	Possible Cause	Remedy	Notes
	<b>Tacho Operation</b>			
7	Shift Light doesn't come on	Shift RPM set to zero or set to high	Set Shift RPM limit to required RPM	
8	Fast Lap/Shift Light comes on when engine starts	Shift RPM set to low	Set Shift RPM limit to required RPM	
9	Displayed RPM reads double on a 2 stroke engine	Cylinders set incorrectly	Enter double the number of cylinders required for 2 stroke engines	(See Setting Cylinders)
10	Displayed RPM value too High or Low by a constant %	Cylinders set incorrectly.	Check the number of cylinders against the Cylinder-Dial chart	See appendix D
11	Displayed RPM value too Low by a factor of two	System is being used on a twin coil ignition system	Set the number of cylinders to half the number of engine cylinders	
12	Fast Lap light doesn't come on.	Shift RPM limit NOT set to Zero	Set Shift RPM limit to Zero	
		Short lap at start of data caused by RUN switch press	Do not press switch once the recording (RUN) has started.	
		Short lap at start of data caused by vehicle stationary in front of beacon	Move beacon to a position where the vehicle would normally not stop.	
13	Tacho resets on power up, then the needle continuously points away from the STACK logo	Internal memory failure	Return to STACK	
14	Tachometer operation is erratic or abnormal	Internal memory has been corrupted by arc-welding on vehicle	Reset Tachometer.	Remove tachometer before arc-welding on vehicle in future.
		Internal memory has been corrupted by excessive interference from HT leads too close to tachometer or harness	Reset Tachometer. Move HT leads away from tachometer or harness.	

No.	Symptom	Possible Cause	Remedy	Notes
	<b>Recorder Operation</b>			
15	RUN light doesn't come ON.	Memory FULL	Download data to PC or Reset tacho memory	
16	RUN light doesn't go OFF at end of run.	Recording was manually started.	Press RUN switch for 3 Seconds until RUN light turns off, or disconnect battery.	This occurs if RUN switch is pressed before the RPM starts the recording.
17	All or some Lap Times Not recorded in data	Red protective cover not removed from receiver	Remove Red protective cover from receiver	
		Transmitter not powered. Battery Dead or not connected	Connect or charge transmitter battery.	Check for Green light on side of Transmitter
		Incorrect alignment of Transmitter	Re align transmitter in accordance with the user guide instructions	
		Transmitter position with the Sun at a low angle <b>behind</b> it.	Move transmitter to face into the sun +/- 90 degrees.	
		Transmitter positioned too close to another Lap timing Transmitter	Move transmitters to be at least 4m, 12ft apart.	
18	Extra Laps recorded. Lap times too short.	More than one transmitter around the circuit	Remove all but one transmitter from the circuit.	

## Appendix D - Cylinder - Dial chart

2 Stroke #Cyls	4 Stroke #Cyls	Dial Face				
		0-5 0-6	0-8 0-10 0-12	0-3-85 0-4-8 0-4-95 0-4-105 0-5-10	0-5-12 0-6-12 0-6-13 0-7-14	0-8-16 0-9-18 0-10-20
	1	250	500	1000	1000	1000
1	2	500	1000	2000	2000	2000
	3	750	1500	3000	3000	3000
2	4	1000	2000	4000	4000	4000
	5	1250	2500	5000	5000	5000
3	6	1500	3000	5250	6000	6000
	7	1750	3500	5500	7000	7000
4	8	2000	4000	5750	8000	8000
	9	2250	4500	6000	8500	9000
5	10	2500	5000	6250	9000	10000
	11	2750	5500	6500	9500	11000
6	12	3000	6000	6750	10000	12000
	13	3250	6500	7000	10500	13000
7	14	3500	7000	7250	11000	14000
	15	3750	7500	7500	11500	15000
8	16	4000	8000	7750	12000	16000

**Note:** operation with settings in the shaded area is NOT guaranteed.

To check the tachometer for how many cylinders it is set for, do the following:

1. Power up the tachometer with the switches pressed.
2. Note the RPM value that the needle is point to and release the switches.
3. Locate the correct dial column for your tachometer in the table above.  
(0-4-8= 0 to 4000 to 8000 RPM non-linear dial face).  
If you have difficulty then the dial code is written on the serial label on the rear of the tachometer.
4. Look down the selected column until you find the closest RPM to your noted value. (You should be able to match the value +/- 50RPM).
5. Follow the row across to the left and read of the number of cylinders for either a 2 or 4 stroke engines as required.
6. If this is NOT the same as the cylinders you require, then use the 'Setting Cylinders' procedure to set the correct number for your engine.

**Warning:** Do not assume that 4000 RPM equals 4 cylinders etc.  
It is not always the case.

## Returned Goods Procedure

In the unlikely event of a Stack part developing a fault and requiring repairs, you are kindly requested to contact your distributor or Stack Ltd for a **Returns Authorisation Number (RAN)**.

A returns goods form and RAN will be supplied by email/Fax/Post to fill in. Please return the faulty part back to Stack Ltd either direct or via the distributor with this completed form.

*Please Note: Returning a part **without** this form and **RAN** will lengthen the repair times and possibly increase the cost of the repair.*

For a current list of distributors log onto the Stack websites at [www.stackltd.com](http://www.stackltd.com) click on the “Where to buy” tab at the top of the home page and select Distributors.



To Contact Stack Ltd:

Email: [sales@stackltd.com](mailto:sales@stackltd.com)

Service Administrator: Tel: +44(0)1 869 240404

Tech Support: +44(0)1 869 240420

Fax: +44(0)1 869 245500

Stack Ltd, Wedgwood Road, Bicester, Oxfordshire, OX26 4UL,  
England.